

# USER MANUAL

## LG SONIC®

### ULTRASONIC ALGAE CONTROL

MODEL

**e-Line**



# 1 Table of Contents

|       |  |
|-------|--|
| 1     | Introduction.....                          |
| 2     | Safety instructions .....                  |
| 3     | Components included .....                  |
| 4     | Installation .....                         |
| 4.1   | Installation of the electronic box.. ..... |
| 4.2   | Installation of the e-transmitters.....    |
| 4.3   | Installation of the float .....            |
| 4.4   | Installation of two units .....            |
| 4.5   | Installation examples of one unit .....    |
| 4.6   | Installation examples of two units .....   |
| 4.7   | Activation.....                            |
| 4.7.1 | Explanation of LCD .....                   |
| 4.7.2 | GSM Activation and Configuration.....      |
| 4.7.3 | Set the pincode of the device.....         |
| 4.7.4 | Request operation status per SMS.....      |
| 4.7.5 | Send test SMS.....                         |
| 4.7.6 | Set Time and Date.....                     |
| 4.8   | Change ultrasonic program.....             |
| 4.8.1 | by control buttons on the e-Box.....       |
| 4.8.2 | Change program by sending an SMS message   |
| 5     | Usage .....                                |
| 6     | Maintenance .....                          |
| 6.1   | Maintenance of the e-box .....             |
| 6.2   | Maintenance of the e-transmitter.....      |
| 7     | Troubleshooting .....                      |
| 7.1   | The results appear negative .....          |
| 7.1.1 | Filamentous algae .....                    |
| 7.1.2 | Roaming algae .....                        |
| 7.2   | The algae are not dying .....              |
| 8     | Guarantee .....                            |

## 1 Introduction

Congratulations on your purchase of the **LG SONIC**<sup>®</sup> algae control solution!

LG SOUND has designed and constructed your **LG SONIC**<sup>®</sup> device to the highest quality standards for years of reliable and accurate service. We hope you will enjoy using this device for a long period.

However, the algae control device can not function properly unless it is installed and maintained in the correct manner. Please read this document carefully in its entirety and follow the instructions for installation and usage of the **LG SONIC**<sup>®</sup> given, in order to ensure optimal performance and the best results.

## 2 Safety instructions

- READ AND FOLLOW ALL SAFETY INSTRUCTION

- 1 Read and follow all instructions that are on the product or provided with the product.
- 2 Do not use an extension cord
- 3 Do not install or use within 10 feet of a pool.
- 4 Reference the National Electrical Code, ANSI/NFPA 70, specifically for the installation of wiring and clearances from power and lighting conductors
- 5 Installation work and electrical wiring must be done by qualified persons in accordance with all applicable codes and standards, including fire-rated construction.
- 6 Do not use in a bathroom.

WARNING: Risk of Electric Shock

- . When used outdoors, install only to a covered class A GFCI protected receptacle that is weatherproof with the power unit connected to the receptacle. If one is not provided, contact a qualified electrician for proper installation. Ensure that the power unit and cord do not interfere with completely closing receptacle cover.

WARNING: Risk of fire, installation involves special wiring methods to run wiring through a building structure. Consult a qualified electrician.

WARNING: Risk of Electric Shock. Mount the unit at a height greater than 1 foot from the ground surface.

- Ensure the power outlet used for the **LG SONIC**<sup>®</sup> has a ground fault circuit interrupter.
- Make sure the entire installation is out of children's reach.
- Never open the electronic box when it is in operation or while it is connected to power.
- Fasten the electronic box at least 1 meters from the edge of the water and ensure it is protected from direct sunlight and rain.
- Never place the electronic box under water to avoid electrocution.
- Handle the transducer with care and protect it from shocks or damage.
- Unplug the unit immediately if any of the two cables or the electronic box is damaged. Contact your dealer for further instructions.
- Always unplug the box before attempting to replace a fuse or perform any repairs, maintenance or other troubleshooting operations.
- Install the devices according to the instructions in chapter 4
- Avoid long term skin contact with the transducer in operation

SAVE THESE INSTRUCTIONS-This manual contains important safety and operating instructions for power units.

## 3 Components

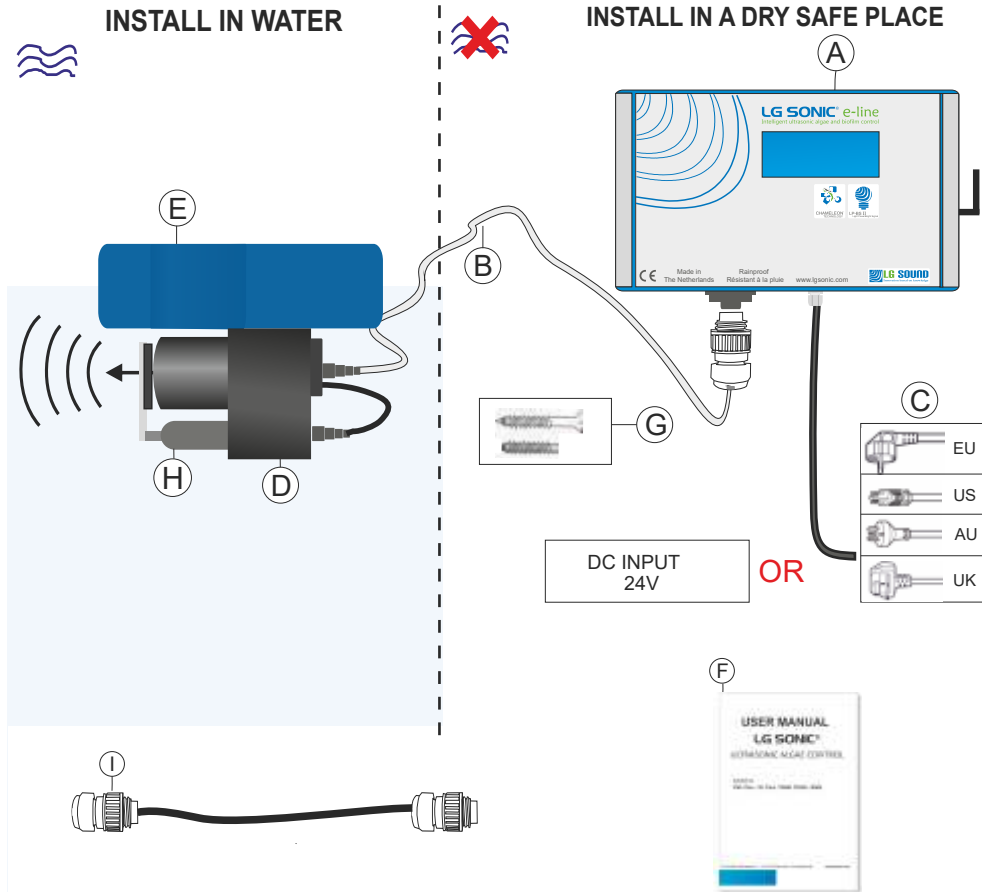

- (A) Electronic box (E-box)
- (B) Transmitter cable
- (C) Power cable
- (D) Transmitter unit  
(Note direction of ultrasonic waves)
- (E) Float
- (F) User manual
- (G) Screw (4p)
- (H) Wiper unit
- (I) Transmitter power supply extension cord  
(Lead) (Optional part, purchased separately)  
50- or 100-foot (15- or 30-metres)

## 4 Installation

Please always check if the voltage on the sticker of the electronic box matches with the plug type and your electricity network before installation. Please contact your dealer immediately if this is not the case.

### 4.1 Installation of the electronic box

The electronic box should be attached to a wall, with the cables facing downwards.

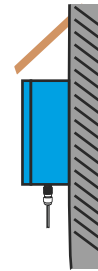

- 1) Remove the design strips on the sides of the box by carefully pulling them on both sides.
- 2) Mark the fixing holes from the electronic box at the place where the box is to be mounted. Drill four corresponding holes into the wall.
- 3) Insert the four supplied screws into the fixing holes of the e-box.
- 4) Mount the electronic box to the wall with the supplied screws.
- 5) Carefully place the design strips back at the sides of the box.



**Make sure the connectors and wires always point down.  
Always install the e-Box in such a way that it is protected  
from direct sunlight and rain. Use a separate enclosure if necessary.**

## 4.2 Installation of the E-Transmitter

The transducer transforms the electrical signals produced by the electronic box into ultrasonic sound signals. These signals are inaudible. The transducer is a very sensitive instrument that needs to be handled with the greatest care.

The ultrasonic sound waves are issued by the transducer in a 180 degrees spread from the front of the machine. The device needs to be placed in such a manner that as much of the water surface as possible comes into direct contact with the sound waves. The strongest ultrasonic signals are those that come straight out of the transducer.

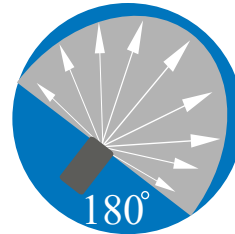

### 1. Determine the optimal location of the transducer:

- Where as much of the water surface comes into direct contact with the sound waves
- Where the front of the unit follows the water current and/or wind direction (for larger water surfaces above 5-10m<sup>2</sup>)
- Where there are no corners outside the reach of the transducer, as this will greatly reduce the effectiveness of the device
- With its backside as close to the water edge as possible

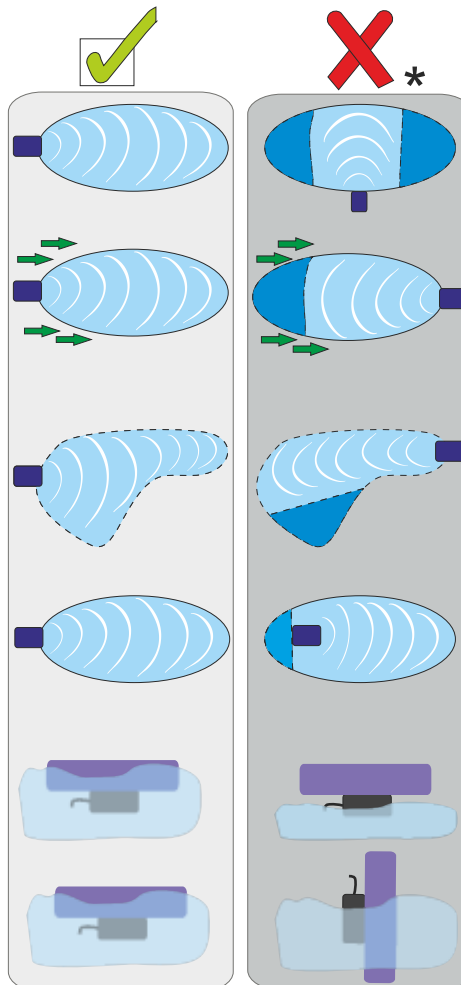

\* Dark area remains untreated

- Place the transmitter in the water
- Ensure that the transmitter is always completely below water surface
- Always ensure a horizontal position of the transmitter

### 4.3 Installation of the float

All the LG Sonic products are provided with a float. This float ensures that the transducer always remains in a position of about 20 cm horizontally below water surface. In this way the sound waves will be reflected when they touch the water surface. The sound will be more efficiently spread throughout the whole water reservoir

The first 20 cm of the water column is where the highest floating algae (unicellular) concentrations can be found, especially during day time.

The float should be secured by means of a pole/spear or rope.

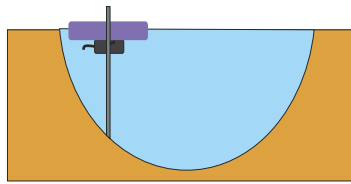

By means of a pole

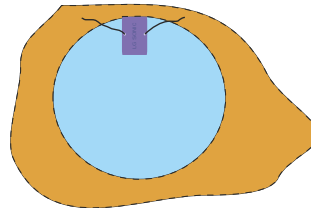

By means of a rope.

### 4.4 Installation of two units

Use multiple transducers when the water surface cannot be covered with one transducer

- a. Never place the transducers facing each other
- b. Never use multiple units if one unit can suffice
- c. It is advised to contact your dealer for advise on the usage of multiple units

**For placement assistance, please visit our website for our Contact details:**

[www.algae-control.com.au](http://www.algae-control.com.au)

## 4.5 Installation examples

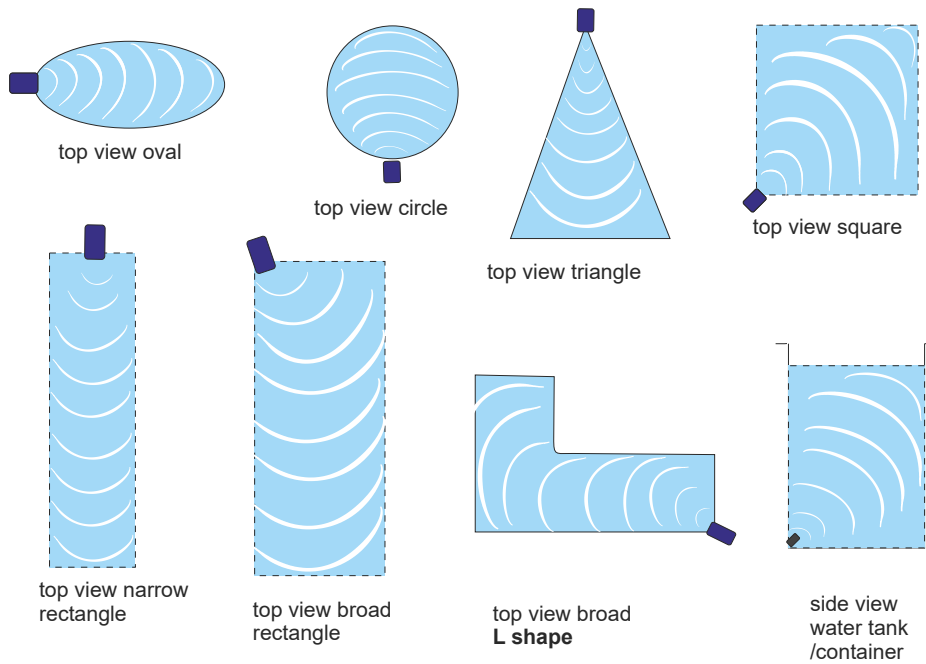

## 4.6 installation examples of two units

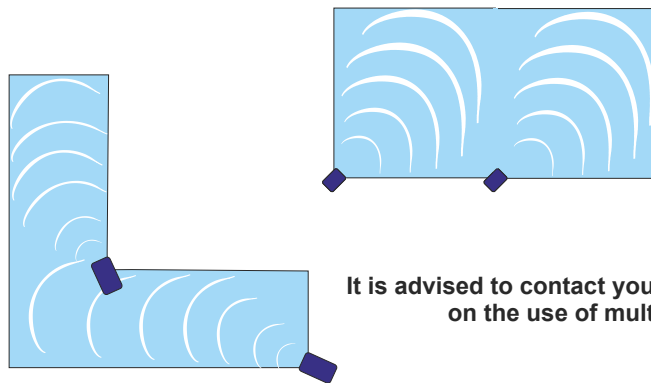

**It is advised to contact your dealer for advice on the use of multiple transmitters.**

For placement assistance, please visit our website for our Contact details:  
[www.algae-control.com.au](http://www.algae-control.com.au)



## 4.7 Activation

1. Connect the transmitter cable(s) to the e-box.

2. Insert the power plug into the power socket.



3. Connect the antenna to the e-Box.

4. The LG Sonic is ready for use.

**It is not necessary to change the program**

### 4.7.1 Explanation of LCD

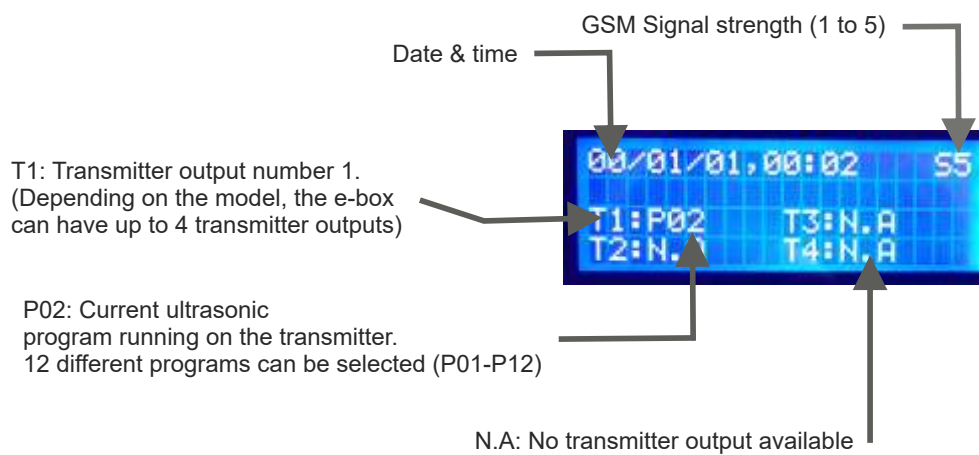

## 4.7.2 GSM Activation and Configuration

The GSM module has 3 functions:

- To change the ultrasonic program of individual transmitter(s)
- To request status
- To receive error alerts.

### 1. Insert SIM Card:

- Press the small button left from the SIM Card holder.
- Gently pull the SIM Card holder from the e-Box.
- Place the SIM Card in the plastic SIM Card holder and place it back into the e-Box.



Make sure there is no pincode on your SIM Card.

Make sure there is enough credit on the SIM Card to send and receive messages.



### 2. Press both buttons simultaneously and hold for 3 seconds.

The following menu will appear:

- 1) **Date & Time** (To edit the Date and Time)
- 2) **SMS Phone Setup** (To setup your mobile number)
- 3) **Send SMS Testing** (To send a "test SMS" to check if the GSM unit is working)
- 4) **Exit Setup**



### 3. Press the "select" button to move the cursor to option 2: "SMS Phone Setup" Use the "enter" button, to entre:

The following menu will appear:

- 1) **Enter Phone No** (To set the GSM unit to your mobile number)
- 2) **Delete Phone No** (To delete the set phone number)
- 3) **SMS Pincode** (Set the pincode for your unit, see section 4.7.3)
- 4) **Exit**

### 4. Use the buttons to select: 1 "Enter Phone No"

Use the "Select" button to choose the digits of your phone number. Use the "Enter" button to select the digit and move to the next.

### 5. The program offers 3 slots where a phone number can be entered.

Select the first slot by pressing the "enter" button once. The cursor now moves to the first digit.

### 6. Exit the menu program and go back to the main screen.

On the main screen: "System Ready" appears.

Always start the number with your country code. Use the "+" symbol to make the country code.

For example: +3161



End the number by selecting 'E' which appears after the '+' symbol.

For example:  
+31612345678E

If the system does not accept the simcard after entering it, unplug the device and plug it in again to reboot the system.

#### 4.7.3 Set the pincode of the device

1. Press both buttons for 3 seconds to enter the main menu.
2. Select option 2: "SMS Phone Setup"
3. In the next menu select 3: SMS Pin Code
4. The pincode will appear behind the menu.
5. The standard pincode is 0000
6. Use the "Select" and "Enter" buttons to set your personal pincode, if necessary.



#### 4.7.4 Request operation status per SMS

By typing a code in your regular SMS screen of your mobile phone, you can request the operation status of your device.

1. Send an SMS to SIM Card number in the e-box, with the code [PINCODE]s

**EXAMPLE: 0000s**

(the standard pincode is 0000 to change the pincode see section 4.7.3)

3. The device will send you a reply SMS.

4. Interpretation of the codes:

- **T1:** Transmitter 1
- **T2:** Transmitter 2
- **T3:** Transmitter 3
- **T4:** Transmitter 4
- **P01/P12:** Ultrasonic program that the transmitter is running on.
- **N.A.:** Transmitter Output Not Available
- **ERROR:** No Transmitter is connected or Transmitter is broken.
- **OFF:** No ultrasonic program selected, transmitter is off.



#### 4.7.5 Send test SMS

A status alert as described in 4.7.4 can be sent to a mobile phone from the menu as well

1. Enter the systems menu by pressing the "Select" and "Enter" button at the same time for 3 seconds.
2. Select option 3: "Send SMS Testing"
3. Press "Enter"
4. On the main screen of the device will appear: "SMS Sent to Phone1"
5. A message will be send to the selected phone number (go to section 4.7.2. to select a phone number)

#### 4.7.6 Set Time and Date

Time and Date are displayed on the main screen. The date and time can be set in the main menu.

1. Enter the systems menu by pressing the "Select" and "Enter" button at the same time for 3 seconds.
2. Select option 1: "Date & Time Setup" and press the "Enter" button
3. Select option 1 by pressing "Enter"
4. By using the "Select" and "Enter" button, set the date first and then the time.

## 4.8 Change ultrasonic program

The transmitters of the LG Sonic e-Line can be set to a specific, preprogrammed ultrasonic program. Depending on the model of the e-Box, the LG Sonic e-Line can support 1, 2, 3, or 4 transmitters that can be programmed independently.

The ultrasonic program can be changed by:

- **Control buttons on the e-Box (4.8.1)**
- **Sending an SMS message (4.8.2)**



The **LG SONIC** e-Line products are all being send with a specific program, as advised by LG Sound.

For an optimal result of the LG Sonic e-Line it is advised to change the ultrasonic program **ONLY** after the recommendation of an LG Sonic representative.

### 4.8.1 Change program by control buttons on the e-Box

On the main display, the 4 transmitters are indicated with T1, T2, T3 and T4.

- Select the Transmitter you want to change by pressing the "Select" button
- Press the "Enter" button.
- By pressing the "Select" button, you can choose from the different frequency programs P01 to P12 and OFF.
- Press the "Enter" button to activate a program.
- The e-Box will confirm with 1 beep.
- A confirmation SMS will be send to the selected phone number  
(For explanation of the code in the SMS find section 4.7.4)

### 4.8.2 Change program by sending an SMS message

Send an SMS to the number of the SIM card inserted in your device with the code:

[PINCODE]t[TRANSMITTER NR]p[PROGRAM NR]

(the standard pincode is 0000 to change the pincode see section 4.7.3)

**For example send code**

To set Transmitter number 1 to program number 4: **0000t1p4**

To set Transmitter number 3 to program number 5: **0000t3p5**

(The e-Box will beep once, if the SMS is received.)

- On the main screen of the e-Box, the SMS message that was sent to the device will appear.
- The program number on the main screen will change.
- The e-Box will send a confirmation message to your phone number.  
(for explanation of the code, please see section 4.7.4)



## 5 Usage

To operate effectively, the **LG SONIC**<sup>®</sup> algae control system must be operating continuously, 24 hours a day. The speed in which the algae are killed will depend on the concentration of algae in your water entity (for example, a lake, reservoir, swimming pool or pond) and the size of your device in relation to the quantity of water. The amount of time that passes until you begin to see results will thus vary from a few days to a few weeks.

Even after the water is cleared from algae, the **LG SONIC**<sup>®</sup> solution will be of use, as algae tend to come back if left untreated. Therefore, the **LG SONIC**<sup>®</sup> device should remain in order, to continue to keep the water mostly clear and free of algae.

After heavy rains new algae might be washed into your water reservoirs . Algae blooms might occur that the **LG SONIC**<sup>®</sup> algae control system will clear in, depending on the amount of algae, a few days to a few weeks.

Different types of algae respond differently to the **LG SONIC**<sup>®</sup> treatment. As certain types of algae die, they will float to the surface and should be removed as often as possible, but at least twice a week, as the blanket of algae will hinder the ultrasonic sound waves. Other algae will sink to the bottom, where they can easily be removed.

Finally, regularly check whether the ultrasonic transducer and the float are still in the optimal position as per section 4.2.

## 6 Maintenance

Work described below can be performed by the user. Please contact your dealer for all technical maintenance and reparation activities .

### 6.1 Maintenance of the e-Box

Frequently inspect the electronic box for damage. Check the connection of power an transducer cable for damages. Damage to the electronic box can cause life threatening situations.

When damage to one or more parts of the **LG SONIC**<sup>®</sup> products is found, first disconnect the device from its power supply and contact your dealer. Your dealer can assist you with professional personnel to repair damages to the product.

## 6.2 Maintenance of the transducer

Clean the front of the transducer, where the ultrasonic sound waves are emitted, once a week. Failure to keep the front of the transducer clean will hinder the ultrasonic waves and ultimately result in reduced effectiveness of your **LG SONIC**® device.

Always disconnect power from the device before cleaning or handling it.

The e-XXL transmitters are standard equipped with a wiper.

This cleans the transmitter head automatically.

The wiper can be purchased optionally on the e-Tank and the e-XL.

When the transducer is covered with calcium scale, use a lightly acid solution to remove it, such as kitchen vinegar.

## 7 Troubleshooting

### 7.2 The results appear negative

#### 7.1.1 Filamentous algae (also known as string algae or blanket weed)

It is not unlikely that the amount of algae seems to have grown after the activation of your **LG SONIC**® system. This is caused by the reduction of the cohesion between the algal cells. The cells are thus less closely connected and will fill up more space.

Living filamentous algae feel very much like a wire and are difficult to pull apart. This changes when the algae are affected: the longer their cells have been dead, the easier they can be pulled apart.

Filamentous algae rise to the surface when they die, where they form a blanket causing the ultrasound waves to be absorbed. This blanket needs to be removed as often as possible, and at least twice a week, in order for the system to continue to operate correctly.

#### 7.1.2 Roaming algae

Algae that grow on the surface of other materials may still be stuck to those surfaces after their demise, appearing as though they were still alive. However, if they are relatively easy to remove from the surface they are on, they are in fact dead. This is not valid for black algae.

Depending on the quantity of the algae, it sometimes takes some time before the algae appear to be dying (even for cyanobacteria, also known as blue green algae). A very simple and effective way to test whether the roaming algae are indeed dead is the 'bottle test'. Fill a bottle with treated water from your reservoir and leave it resting for 24-48 hours in a quiet place. The bottle should not be closed and daylight should be included.

If the algae have sunk to the bottom or are now floating on the surface, they are dead. However, if the water remains greenish and unclear, the treatment has not yet worked.

Find the next section for instructions.

In a pond, where there is constant water movement (because of wind, fish, filters, fountains, and so on) it may take weeks before the algae are visibly dead.

## 7.3 The algae are not dying

### 1. Check whether the e-Box is in operation:

#### a. Check the LCD

- Check if the LCD is on.
- Check if the transmitters are running a program (section 4.7.1).  
If a transmitter is broken or off, the words “**ERROR**” or “**OFF**” are shown on the LCD behind the transmitter number (T1 - T4)
- Check If one of the Transmitters shows “OFF” follow section 4.8 to program the transmitter.

#### b. Request operation status by SMS, see section 4.7.4

### 2. Check whether the center of the front of the transducer (about 2 cm in diameter) is clean

#### a. The transducer appears to be clean

- The transducer is working

#### b. If the transducer is not clean and a calcium-like layer or biofilm has formed:

- The sound waves are not properly emitted
- Clean the transducer with an acidic solution such as kitchen vinegar

#### c. If your device is equipped with a wiper, check if the wiper is still working, if not, contact your dealer.

### 3. If the Transmitter is clean and emitting an ultrasonic program, we can change the ultrasonic program to match the algae in your water.

- a. Contact your dealer, inform him from the algae in your water, by explanation or sending him a picture.
- b. Your dealer will advise you the most optimal ultrasonic program.

## 8 Guarantee

LG Sound, producer of the **LG SONIC**® device, has great confidence in its products and guarantees the quality of assembly and materials used. The warranty limits itself to material- and construction faults and has a term of TWO YEARS for the LG Sonic E-box

In this period the necessary replacement of, by material- and/or construction faults, failing parts will be made available at no cost to the purchaser. Every additional claim on the warranty, compensation or consequential damage included, are here explicitly made exempt.

The above mentioned warranty is only valid under these conditions:

1. The device must be correctly installed following the instructions in this manual.
2. Every claim to the warranty becomes void when repairs, changes, adjustments or assemblies are made using parts that are not supplied by LG Sound or have not been approved of prior in writing. In addition, every claim becomes void if installation took place that did not comply with the local regulations.
3. The warranty is valid for normal use following the installation instructions. Damage resulting from usage for other means than for which the device is intended, overburdening, neglect or normal wear and tear are hereby made explicitly exempt.
4. Claims made during the period of warranty do not result in this period being extended
5. Every claim to warranty becomes void if the device is not cleaned at least once a year
6. Any expedition costs are to be carried by the buyer
7. The warranty can only be honoured if the statement of defect is accompanied by a copy of the invoice or proof of payment and a description of the defect.

